

VERTICAL INTEGRATION OF INCENTIVES FOR COOPERATION - INTER-LAYER COLLABORATION AS A PREREQUISITE FOR EFFECTIVELY STIMULATING COOPERATION IN AD HOC NETWORKS¹

Philipp Obreiter, Michael Klein

Institute for Program Structures and Data Organization, Universität Karlsruhe, D-76128 Karlsruhe, Germany

eMail: {obreiter, kleinm}@ipd.uni-karlsruhe.de

<http://www.ipd.uni-karlsruhe.de/DIANE>

Abstract.

In ad hoc networks, devices must cooperate in order to compensate for the absence of infrastructure. Yet, autonomous devices are free to decide whether to cooperate or not. Hence, incentives are indispensable to induce cooperation between autonomous devices. Recently, several incentive schemes have been proposed. Each of them is focussed on incentives for cooperation on a specific protocol layer. In this paper, we demonstrate the ineffectiveness of such isolated incentive schemes and point out the need for vertical integration. Therefore, vertical interaction of protocol entities is augmented by exchanging the state of different layers' incentive schemes. This builds the foundation of a generic model of stimulated cooperation that captures inter-device cooperation and inter-layer interaction in the presence of incentives for cooperation. The proposed model is exemplified and its concept of localizing resource consumption is illustrated. We examine the applicability of the model to existing protocols and incentive schemes by considering three dimensions of heterogeneity and discussing implementation issues. Lastly, we sketch an incentive scheme that applies vertical integration of incentives for cooperation in our research project DIANE.

1 Introduction

Conventional networks know two types of devices. The first type of devices is infrastructural. Such devices ensure the operativeness of the network's services. For instance, dedicated repeaters, bridges, routers, gateways, and servers are such infrastructural devices. The second type of devices is appendant to end users. Such devices make use of the network on behalf of their users. Mobile phones are a good example of end user devices.

In the recent years, the need for infrastructureless networks has been conjectured for some application areas, thus leading to the formation of a research community for ad hoc networks. In the absence of infrastructural devices, the end users' devices have to take over infrastructural tasks in order to ensure

the network's effectiveness. Therefore, cooperation among end users' devices becomes necessary. However, the absence of infrastructure implicates the lack of any centralized authority that enforces cooperative behavior of the participating devices. Therefore, the user assumes full control of his device's behavior. As a result, from a network point of view, the participating devices are autonomous and, thus, they are free to decide whether to cooperate or not.

Due to the harsh resource constraints of wireless and/or mobile devices, the participating devices tend to maximize their resources' utility by exhibiting selfish behavior. Therefore, it has been suggested to apply incentives for inter-device cooperation. In [12], existing incentive schemes for ad hoc networks are surveyed. As the paper illustrates, incentive schemes are confined to the cooperation of network protocol entities. Furthermore, for the provision of application services, there exist network independent incentive schemes that are better known as electronic payment systems [1]. On top of that, economic and societal incentive schemes stimulate cooperation among users.

Layered cooperation and incentive schemes. According to [13], cooperation is layered as shown in Figure 1. In order to facilitate the systematic consideration of user cooperation and device cooperation, each user is represented by a protocol entity of the conceptual user layer.

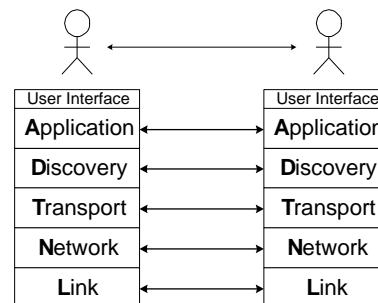

Figure 1. Inter-device cooperation of protocol entities

¹ The work done for this paper is partially sponsored by the German Research Community (DFG) in the context of the priority program (SPP) no. 1140.

Obviously, there exists a gap between user, application and network layer incentive schemes. The vertical integration of incentive schemes is only considered sporadically, e.g. by converting virtual currencies of the network and application layer to real world money [2][17][1]. However, these approaches fall short of systemically integrating incentive schemes among layers.

Apart from integrating existing incentive schemes, the lack of any incentives for cooperation on the discovery, transport and link layer becomes apparent. If protocol entities on certain layers are exempted from enforcement of cooperative behavior, cooperation on the remaining layers might become impossible. For instance, in the absence of an effective discovery infrastructure, application services cannot be found and consumed. In such a case, the presence of an incentive scheme for the provision of application services is of no importance.

Autonomy. It is assumed that devices are autonomous with respect of their decision to cooperate or not with other devices. Therefore, inter-device collaboration goes beyond the autonomy border and has to be stimulated. Obviously, the set of protocol entities is partitioned vertically with respect to their autonomy. Intra-device collaboration, i.e. interaction of a device’s protocol entities, remains within the autonomy border and, thus, does not have to be stimulated. In the following, inter-device collaboration is called *cooperation*, whereas intra-device collaboration is referred to as *interaction*.

Outline. The remainder of this paper is structured as follows: In Section 2, we identify the need for vertical integration of incentive schemes. In order to facilitate vertical integration, we extend the basic model of vertical interaction in Section 3. As a result, we propose and exemplify a generic model of stimulated cooperation beyond device and layer borders in Section 4. In Section 5, the applicability of the proposed model is examined and, in Section 6, we sketch vertical integration of incentives for cooperation in our research project DIANE. Finally, in Section 7, we conclude the paper.

2 Cooperation within a Layer

In this section, we examine the need for vertical integration of incentives for cooperation. Therefore, we take a closer look at inter-device cooperation and cooperation patterns within a layer. We are then in the position to identify the consequences of confining incentive schemes to a single layer.

2.1 Elementary Cooperation

A precise analysis of cooperation among protocol entities reveals the roles that a protocol entity may assume. In [12], it is pointed out that cooperation among protocol entities may be decomposed into a set of elementary cooperations.

As the elementary constituent of cooperation, an entity *A* acts on behalf of an entity *B*. In the following, entity *A* is called *agent entity* and entity *B* is referred to as *principal entity*. The action is part of the entities’ protocol and is beneficial to the principal entity. For example, a network protocol entity, i.e. the agent entity, forwards packets on behalf of its sender, i.e. the principal entity. Therefore, the principal entity remunerates the agent entity and, thus, stimulates the

agent entity’s action. In the following, cooperative behavior is treated on the elementary principal-agent level. Figure 2 interrelates the proposed terms.

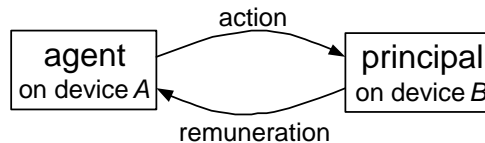

Figure 2. The terminology of elementary cooperation

In a service oriented perspective, the agent entity is the provider of a service, i.e. the action, and the principal entity is the consumer.

2.2 Cooperation Patterns

In ad hoc networks, cooperation tends to asymmetry, i.e. there exist protocol entities that are inherently principal or agent entities. For instance, network protocol entities on the edges of the ad hoc network are inherent principals, since they are not required for packet forwarding. On the other hand, in hierarchical discovery protocols [9] [8] [7] [6], discovery protocol entities that are rich in resources are likely to assume a predominant role and, consequentially, they are inherent agents. More generally speaking, asymmetric cooperation patterns stem from the inherent asymmetry with regard to the network’s topology and the devices’ resources and usage patterns.

Inherent asymmetry is closely related to venial noncooperation [12]. However, inherent asymmetry may be determined objectively, whereas venial noncooperation is contingent on subjective assessment of admissible behavior. Take for example a device that holds together two parts of an ad hoc network. Figure 3 illustrates such a topology and depicts the device as *B*. Its network protocol entity represents a routing bottleneck, so that it is an inherent agent. In such a case, inherent asymmetry is prevalent in the network. Yet, if due to its load the network protocol entity of device *B* occasionally drops packets, its uncooperative behavior may or may not be considered as venial noncooperation. Such an assessment is subject to the participants’ policy.

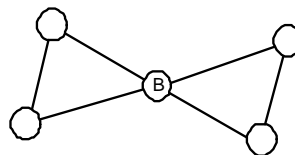

Figure 3. Topology with routing bottleneck

2.3 The Need for Vertical Integration

Cooperation within a layer is composed of elementary cooperations. Therefore, a protocol entity is not restricted to as-

sume a certain role all the time. It acts as principal entity in some elementary cooperations whereas acting as agent entity in some others.

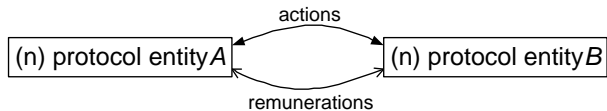

Figure 4. Stimulated cooperation in a layer

Figure 4 illustrates stimulated cooperation within the layer n . The regular arrowheads depict the exchange of remunerations. In this context, a protocol entity is stimulated to act as agent entity in order to be able to remunerate while acting as principal entity.

However, such stimulation comes with two disadvantages. They arise from isolating remunerations of different layers. On the one hand, the scope of an incentive scheme is restricted to a single layer, which might call for an unnatural conception of the incentive scheme. On the other hand, asymmetric cooperation patterns are not taken into account, so that the effectiveness of the incentive scheme is undermined.

2.3.1 Inter-layer Incentive Schemes

It might make sense that the incentive scheme encompasses several layers and, thus, does not differentiate between some protocol entities of a device. Then, such protocol entities are jointly in possession of their remunerations. For example, it is possible to conceive a reputation based incentive scheme that assigns reputation to devices and, thus, not to single protocol entities. In such a case, the segregate treatment of a protocol entity is not reasonable.

Furthermore, the restriction of incentive schemes to a single layer isolates the user from the device's protocol entities. For instance, in a reputation based incentive scheme on the application and user layer, the application protocol entity and the user have to exchange their views of other entities' reputation through the user interface, which calls for vertical integration of incentives for cooperation.

2.3.2 Asymmetric Cooperation Patterns

If a protocol entity is an inherent principal or inherent agent, cooperation becomes asymmetric. Consequently, the flow of remunerations within the respective layer is inherently directed. On the one hand, inherent principals run out of remunerations and, thus, cannot act as principal entity any more. On the other hand, inherent agents cannot be stimulated any more after having acquired a sufficient amount of remunerations. In both cases, the incentive scheme ceases to be effective.

The problem of asymmetric cooperation patterns arises from the segregate treatment of single layers. However, a protocol entity's abundance of remunerations may be counterbalanced by the need for remunerations of another protocol entity on the same device. E.g. a mobile phone might provide

internet access on the application layer, so that it holds sufficient remunerations in order to act as inherent principal in the remaining layers.

If the device's protocol entities as a whole are inherent principals or inherent agents, the lack or abundance of remunerations has to be counterbalanced by the user. For instance, a PDA user might pay for the operation of its inherent principal protocol entities, whereas the operator of the printer is able to earn money in order to compensate for its operating costs. In any case, the effectiveness of the incentive scheme requires vertical flow of remunerations, which calls for vertical integration of incentives for cooperation.

3 Vertical Interaction as a Means of Vertical Integration

After having pointed out the need for vertical integration of incentives for cooperation, we identify means of vertical integration in this section. Vertical integration lays stress on vertical interaction of protocol entities. As a starting point, we model inter-layer interaction as an exchange of resources and services. In order to facilitate vertical integration, this basic model is augmented with vertical trading of remunerations.

3.1 Vertical Interaction

A user acquires his device and maintains its resources since he aims at making use of it. The other way round, the protocol entities of his device consume available resources in order to provide the services that are requested by the user. Apparently, the user-device interaction has two purposes that have to be supported by the user interface: resource configuration and service consumption. On the one hand, the user assesses resources, so that the device's protocol entities are aware of the value of the resources that they consume. In this respect, the user determines his protocol entities' behavior by such resource assessment. On the other hand, the user interacts with the application protocol entity and, thus, consumes the services it offers.

We suggest resource assessment as the glue of entity level decision making. Such an approach is closely related to Agoric Computing [4]. If each entity is aware of the scarcity/preciousness of the respective resources, it is able to adapt its resource consumption patterns in order to execute its task accordingly. In this regard, the evaluative nature of the entities is revealed. During decision making, each entity is aware of several resource tradeoffs [10] so that, the assessment of the respective resources given, it is able to determine the most efficient way to process its task.

The notion of resource assessment may also be applied to the services that are provided to the upper entity. Apparently, this becomes necessary if entities consume added value services and, thus, are not aware of the resources they implicitly consume. In such a case, each entity has to assess the value of the services that it provides by estimating the resources that it requires therefor. Consequently, service assessment is derived from resource assessment and may be treated accordingly. Therefore, in the following, we will focus on resource assessment.

Resource assessment consists of a static and an adaptive part. The user statically assesses the scarceness of every resource regardless of its transient usage. E.g. the user of a mobile phone might assign high values to its computational resources. In addition, the user assigns a value function that introduces adaptivity to resource usage, so that resources of heavily loaded devices become more expensive. The configuration of resource values has to be performed whenever the user's assessment changes. For instance, it makes sense to rise anticipatorily the value of resources for a trip without opportunities of battery recharging.

The interaction of the user and his device is illustrated in Figure 5. In this context, the provision and consumption of services refers to vertical interaction of protocol entities. Contrarily, application services depict horizontal, i.e. inter-device, cooperation on the application layer.

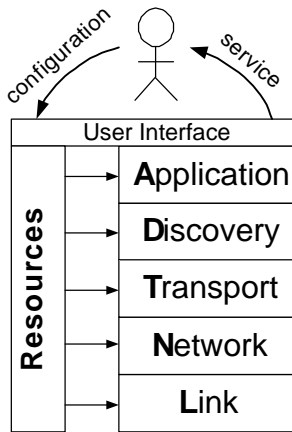

Figure 5. User-device interaction

The user relinquishes resources to the application protocol entity in order to consume its services. The other way round, the application protocol entity partially leaves the available resources to the discovery protocol entity, since the discovery layer's services are required in order to provide the application layer's services for the user. More generally speaking, the protocol entity of layer $n+1$ relinquishes resources to the protocol entity of layer n in order to consume its services. Figure 6 shows such vertical interaction of resources and services. In this context, relinquishing resources is a prerequisite for the effective consumption of the lower layer's services. Nevertheless, leaving resources does not constitute an incentive for service provision, since the lower layer's protocol entity is not autonomous and, thus, does not require stimulation.

3.2 Vertical Trading of Remunerations

In order to allow for vertical integration, vertical interaction of protocol entities has to go beyond the exchange of resources and services. Remunerations hold the state of their respective incentive scheme. Therefore, trading remunerations beyond layer borders provides a means of vertical integration.

In order to do so, remunerations are not only handed over within a layer, i.e. from the principal entity to the agent en-

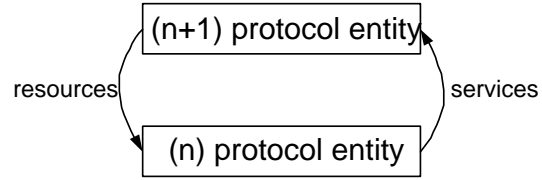

Figure 6. Vertical interaction of resources and services

tity, but they are also vertically exchanged between protocol entities of the same device. Therefore, the vertical interaction of Figure 6 is enhanced in order to consider vertical trading of remunerations, as shown in Figure 7. Again, the regular arrowheads depict the trade of remunerations.

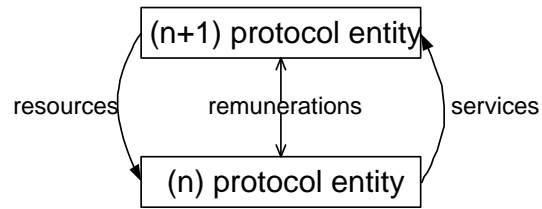

Figure 7. Vertical trading of remunerations

In contrast to resources and services, the vertical flow of remunerations is generally bidirectional. It occurs whenever the stimuli of cooperation are not self-contained within a layer. Yet, it is neither required that remunerations are traded in the context of an exchange of resources and services nor vice versa. Therefore, there exists no direct connection between the vertical trading of remunerations and the exchange of resources and services. For instance, there might several exchanges of resources and services before, finally, remunerations are traded vertically in order to restore the balance of remunerations.

If the protocol entity of layer n is in abundance of remunerations and the protocol entity of layer $n+1$ lacks remunerations, then remunerations are turned over from n to $n+1$. For instance, the application protocol entity of a printer might earn money for its operator in order to compensate for its operating costs. Hence, an inherent agent turns over acquired remunerations to the upper protocol entity and, thus, recompenses it for having consumed resources without providing services to it. In this regard, the vertically traded remunerations stimulate the upper protocol entity to relinquish resources to the lower protocol entity.

On the other hand, remunerations are turned over from $n+1$ to n , if the protocol entity of layer n lacks remunerations and the protocol entity of layer $n+1$ is in abundance of them. For example, a PDA user might have to pay its device's application protocol entity, so that it is able to remunerate application protocol entities of other devices that act as agent on its behalf. Therefore, an inherent principal necessitates an inflow of remunerations from its upper protocol entity in order to provide services while consuming a minimum of resources. In this context, the vertically traded remunerations stimulate

cooperation on the lower layer.

Figure 8 shows the vertical trade of remunerations in the presence of inherent principals and inherent agents. The dotted line illustrates the fact that inherent principals require minimal resources in order to provide a service for the upper layer’s protocol entity. Since each protocol entity requires some resources in order to operate, we will omit the dotted line in the following.

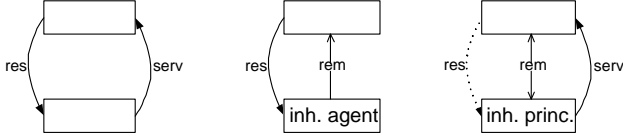

Figure 8. Behavioral patterns: self-contained, inherent agent/principal

Vertical trade ensures the effectiveness of the incentive scheme in the presence of asymmetric cooperation patterns. In addition, vertical trading of remunerations copes with venial noncooperation up to a certain degree. For instance, in a reputation based incentive scheme, the reasonability of a device’s failure to cooperate may be assessed by the concerned users in the vicinity.

In case of vertical trading of remunerations, behavioral patterns only depend on subjective cost/benefit functions that relate resources and spent remunerations to services and acquired remunerations. Therefore, the behavior of a protocol entity is not only subject to the remunerations it possesses. Even for users that are in possession of enough real world money in order to enable its protocol entities to become inherent principals, there is threshold of the actions’ remunerations beyond which its protocol entities are willing to act as agent entity.

4 A Generic Model of Stimulated Cooperation

Vertical trading of remunerations interrelates interaction and cooperation, since they both initiate the exchange of remunerations. Therefore, it seems promising to make this relationship explicit by combining the models of cooperation (Section 2) and interaction (Section 3). Consequently, in this section, we propose and exemplify a generic model of stimulated cooperation that captures inter-device cooperation and inter-layer interaction in the presence of incentives for cooperation.

4.1 Example: Printing a Document

In the following, we exemplify stimulated cooperation that stretches across several devices and layers.

Consider a PDA user P who prints a document on a printer that is operated by user O . Therefore, user P interacts with the PDA’s application protocol entity ($A-PE$) in order to consume a service, i.e. print the document. In order to provide the demanded service, the $A-PE$ has to cooperate with the $A-PE$ on device O , i.e. the printer. As a prerequisite, the operator of the printer permits his $A-PE$ to act as agent by relinquishing resources, i.e. maintaining the printer and providing ink and paper.

Figure 9(a) illustrates the cooperation that results in printing the document. Obviously, the PDA’s $A-PE$ will lack remunerations if the PDA user prints several documents. The opposite is true for the printer’s $A-PE$ since it amasses remunerations. In such a case, both PDA and printer require vertical trading in order to further cooperate effectively. This is shown in Figure 9(b).

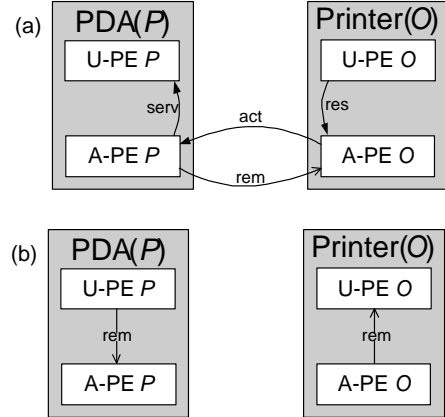

Figure 9. (a) Printing a document; (b) vertical trading of remunerations

Let us assume that the transmissions of the PDA cannot be received by the printer and vice versa. Therefore, the devices’ communication is routed via a third device R , i.e. a router. As a precondition, the user R relinquishes resources to his network protocol entity ($N-PE$), so that it is able to act as agent for the $N-PE$ of the PDA and the printer by forwarding their packets.

In Figure 10(a), we illustrate the cooperation that arises from the communication between the $A-PE$ of the PDA and the printer. Again, if such cooperation occurs frequently, vertical trading becomes necessary in order to enable further cooperation, which is shown in Figure 10(b). For clarity, the transport and discovery protocol entities of the PDA, router and the printer and the application protocol entity of the router are omitted. They would pass on the vertically traded remunerations and the exchanged resources and services.

The combination of cooperation that aims at printing (Figure 9) and routing (Figure 10) is shown in Figure 11. In the figure, it is assumed that the ensuing disparity of remunerations is immediately compensated by vertical trading.

Expectedly, the operators of the router and the printer are both willing to relinquish resources to their $A-PE$ in order to obtain remunerations. Moreover, the $N-PE$ of the PDA and the printer are both inherent principals. Obviously, protocol entities of the same device may assume different roles, e.g. the $N-PE$ of the printer is an inherent principal, whereas its $A-PE$ is an inherent agent.

Figure 12(a) shows the transformation of resources into actions and, finally, into services. The arrows’ weight illustrates the amount of resources and the value of actions and services. Obviously, the resources of the PDA, router and printer disembody into the service provided by the $A-PE$ of the PDA.

Figure 12(b) shows the flow of remunerations. In this context, the arrows’ weight depicts the amount of remunerations.

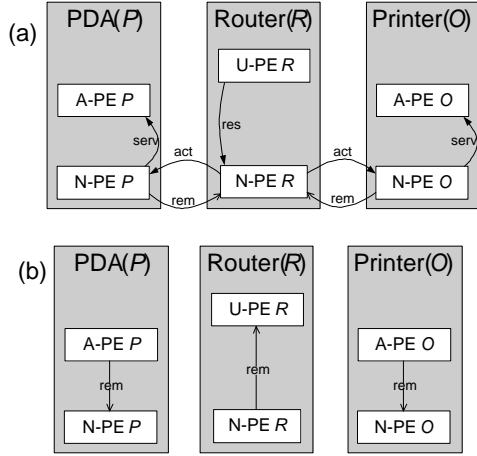

Figure 10. (a) Routing the devices' communication; (b) vertical trading of remunerations

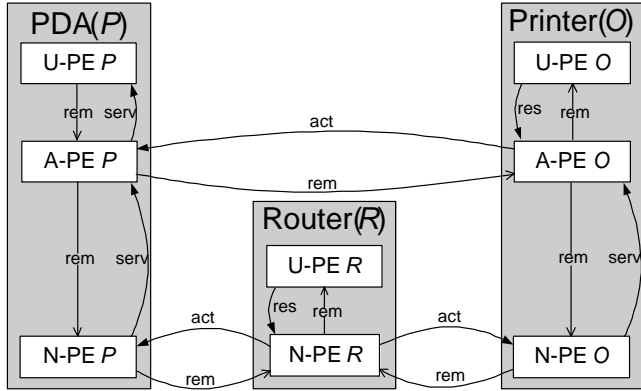

Figure 11. Example of stimulated inter-layer cooperation

The flow is directed from its source, i.e. the PDA user, to its sinks, i.e. the operators of the router and printer. Therefore, the operators are remunerated by the user for having contributed to provide the demanded service, i.e. printing the document.

4.2 The Model

Before introducing the generic model of stimulated cooperation, we discuss a straightforward combination of cooperation and interaction. Let us assume that the user requests a service from his application protocol entity. Then, the entity has to decide whether the disposable resources suffice or whether it has to cooperate with other application protocol entities in order to provide the demanded service. The latter case is called *hidden cooperation*. In any case, from the user perspective, the application protocol entity transparently provides the demanded service. Hidden cooperation may occur in every layer below the user layer. Figure 13 illustrates an elementary cooperation in the presence of vertical interaction. The vertical flow of remunerations is directed since it compensates for lack

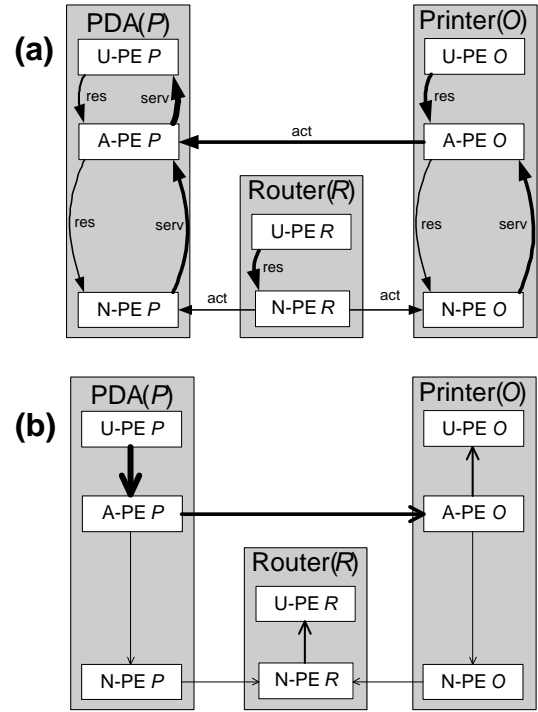

Figure 12. (a) Transformation of resources, actions and services; (b) Flow of remunerations

of resources or services. The key characteristic of hidden cooperation is that the protocol entities of layer n might not be aware of the cooperation on the lower layer. In the example of Section 4.1, there is a hidden cooperation between the PDA user and operator of the printer.

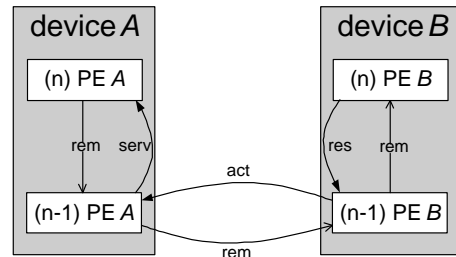

Figure 13. Hidden Cooperation

The combination of explicit and hidden cooperation brings forth a generic model of stimulated cooperation. The model is illustrated in Figure 14. It combines the inter-layer interaction of Figure 7 and the inter-device cooperation of Figure 4 in order to propose a generic model of stimulated cooperation. Obviously, hidden cooperation is a special case of stimulated cooperation and, thus, it is comprised within the model.

4.3 Remunerations as Virtual Resources

It becomes apparent from Figure 12 that remunerations compensate for resources. Therefore, it seems promising to exam-

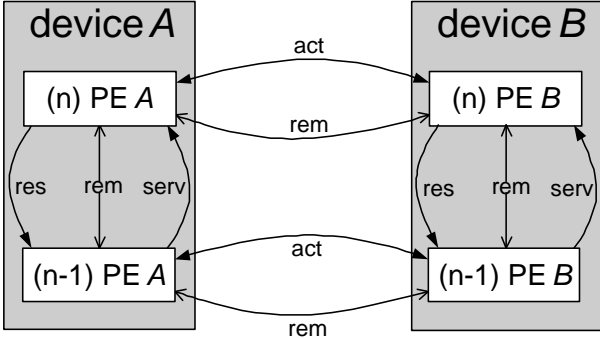

Figure 14. Inter-layer interaction and inter-device cooperation

ine the relationship of remunerations and resources.

If we take a closer look at local service provision (Figure 6) and distributed service provision by the means of hidden cooperation (Figure 13), the interrelation becomes evident. By distributing service provision, the vertical interaction of resources and services is decomposed. On the one hand, resources of device B are utilized for the provision of the service on device A. On the other hand, remunerations of device A are handed over to device B in order to compensate for the consumed resources. In this regard, remunerations are substitutes of resources and may be depicted as *virtual resources*.

If we do not distinguish between resources and remunerations, resource consumption is localized on the user’s device regardless of whether service provision is local or distributed. This stems from the zero-sum situation for the operators that acquire virtual resources while consuming their resources.

We have to note that, alternatively, remunerations may be depicted as virtual services. Then, service consumption is localized on devices that consume resources. This time, there is a zero-sum situation for the user who acquires services while consuming virtual services. Even though such a perspective is as legitimate as the aforementioned one, it appears to us that the notion of virtual resources is more intuitive.

5 Applicability of the Generic Model

The generic model of stimulated cooperation abstracts from two practical problems. On the one hand, incentives for cooperation are heterogeneous with regard to their remunerations and layers. On the other hand, the model introduces vertical trading of remunerations which is purely conceptual and brings on implementation issues. In this section, both practical problems are discussed.

5.1 Homogeneous and Heterogeneous Stimulated Cooperation

The integration of different incentive schemes yields an overall incentive scheme that we call *integrated incentive scheme*. The integrated incentive scheme of the generic model is homogeneous and, thus, it makes several assumptions that we explain in the following.

There are several patterns of stimulating cooperation, e.g. reputation based or account based patterns [12]. We refer to

them as *incentive patterns*. They are analyzed and discussed in our previous work [14]. Obviously, the integrated incentive scheme assumes that the incentive schemes all apply exactly the same incentive pattern in order to stimulate cooperation. Otherwise, vertical trading requires compatible incentive patterns. Furthermore, the model presumes that remunerations are acquired and stored by the agent entity. This assumption holds for trade based incentive patterns [14], e.g. for checks. Finally, the model assumes exactly one incentive scheme on each of the six layers. Figure 15 illustrates the *homogeneous* stimulated cooperation that the generic model assumes.

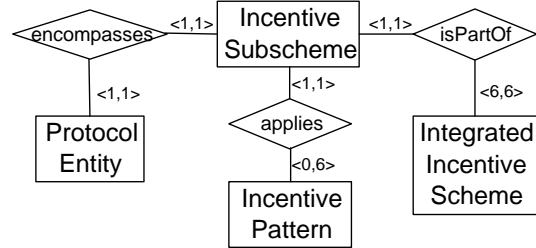

Figure 15. E-R-diagram of homogeneous stimulated cooperation

In practice, vertical integration of incentive schemes has to take their heterogeneity into account. Figure 16 shows that *heterogeneous stimulated cooperation* introduces three dimensions of heterogeneity: the relationship of incentive schemes to layers, incentive patterns and the integrated incentive scheme respectively.

In this context, an incentive scheme is defined as a constituent of the integrated incentive scheme that applies exactly one incentive pattern and that does not differentiate between a device’s protocol entities of layers that it encompasses.

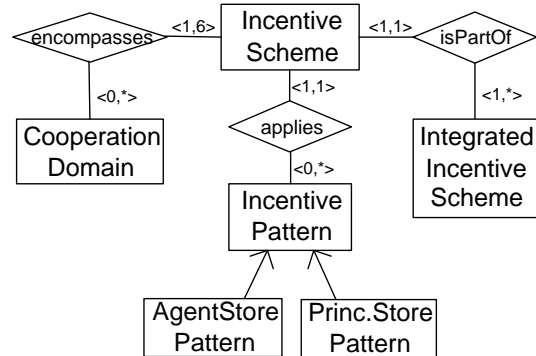

Figure 16. E-R-diagram of heterogeneous stimulated cooperation

Incentive schemes and layers. As we already pointed out in Section 1, some layers lack any incentive scheme, whereas other layers are stimulated by several incentive schemes. From an incentive scheme’s perspective, this statement translates as follows: On the one hand, an incentive

scheme is not required to encompass exactly one layer. For instance, there are incentive schemes that stimulate cooperation on several layers [12]. Then, the set of layers is horizontally partitioned by the incentive schemes. On the other hand, a protocol entity may be stimulated by several schemes. For example, the user is stimulated by economic and societal incentive schemes. In such a case, cooperation is vertically partitioned by the incentive schemes. Finally, a protocol entity may lay outside the scope of any incentive scheme. In Figure 16, horizontal and vertical partitioning is illustrated by the cardinalities $\langle 1,6 \rangle$ and $\langle 0,* \rangle$ respectively.

In the example of Section 4.1, cooperation on the application layer and the network layer might be stimulated by an account based and a reputation based incentive scheme, whereas other layers, e.g. the link layer, are not stimulated. In such a case, stimulated cooperation is partitioned horizontally. On the other hand, stimulated cooperation is partitioned vertically, if a protocol entity lies within the scope of several incentive schemes. For instance, the application protocol entity of the PDA might be stimulated by another reputation based incentive scheme which allows for cooperation of the PDA user with his friends.

Incentive schemes and the integrated incentive scheme. Vertical integration of incentive schemes has to consider a portfolio of one or more incentive schemes which is reflected by the $\langle 1,* \rangle$ cardinality in Figure 16.

Incentive schemes and incentive patterns. There is an incentive patterns that stores remuneration on the principal entity, i.e. the community pattern [14] which is based upon reputation. Therefore, the set of incentive patterns is partitioned with regard to the storage site of remunerations. As a result, inter-scheme trading, i.e. vertical trading of remunerations across the border of incentive schemes, demands for specific mechanisms that overcome a possible mismatch of the remunerations' storage site. Yet, even if every incentive scheme applies the same incentive pattern, inter-scheme trading requires mechanisms that enable incentive schemes to assess and trade remunerations among each other. For instance, in case of unequal weighting of remuneration in different incentive schemes, their remunerations may be traded according to an exchange rate.

In contrast to the homogeneous stimulated cooperation of Figure 15, an incentive pattern might not longer be applied by either all or none of the incentive schemes. This is shown by the $\langle 0,* \rangle$ cardinality of Figure 16.

5.2 Implementation Issues

The challenge of implementing vertical integration arises from vertical trading of remunerations.

5.2.1 Vertical Trading in Homogeneous Stimulated Cooperation

In a first step, we discuss vertical integration of homogeneous incentive schemes. This provides a sound basis for the consideration of heterogeneity.

Implementation issues of horizontal trading of remunerations are studied in [12]. In general, vertical trading cannot

be performed locally. The only exception is the reputation based incentive pattern that takes advantage of its inherent localization of remuneration assessment and storage. In contrast, an account based incentive pattern does not allow for localized vertical trading, since checks cannot cross the borders of incentive schemes.

This principle is illustrated in Figure 17. In order to trade remunerations from protocol entity (n) to $(n-1)$ on device A , a second device B is required which wants to perform the trade in the other direction. This stems from the closed property of incentive schemes. Given the fact that $(n-1)$ protocol entity on device A needs remunerations because it is an inherent principal, there exists at least one device the $(n-1)$ protocol entity of which is in abundance of remunerations. As a result, vertical trading may be incorporated within the framework of transactions [12]. In this context, the action of device B 's (n) protocol entity consists of initiating the transfer of its $(n-1)$ protocol entity's remunerations to device A 's $(n-1)$ protocol entity. In order to complete the transaction, device A 's (n) protocol entity hands over remunerations to device B 's (n) protocol entity.

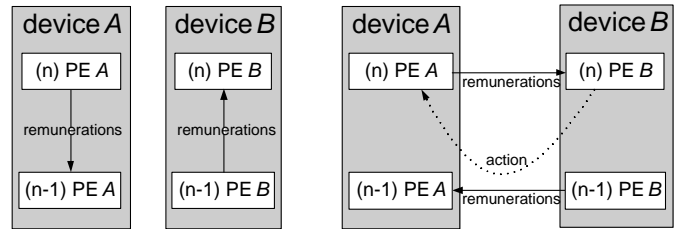

Figure 17. Vertical trading in the conception and implementation

Even if incentive schemes are self-contained, vertical trading is required for bootstrapping. For instance in account based patterns, the user has to pay for the establishment and initial balance of his account. In such a case, the device of the operator naturally assumes the role of device B .

The mechanisms are also applicable, if remunerations have to be traded to upper protocol entity. In fact, this is the case in Figure 17 from device B 's perspective.

5.2.2 Vertical Trading in Heterogeneous Stimulated Cooperation

We already discussed vertical integration in the presence of a portfolio of incentive schemes. The existence of inter-scheme trust mechanisms is a prerequisite for such trading. Furthermore, remunerations have to be carefully interrated in order to sustain the effectiveness of the incentive schemes. Apart from that, there remain two other dimensions of heterogeneity for discussion.

Incentive schemes and layers. From an inter-scheme trading point of view, horizontally partitioned layers are not distinguishable from vertically partitioned ones. In any case, trading remunerations implicates a pair of remuneration transfers. Therefore, it does not matter whether the transfers

occur in the same layer or in different (and possibly not adjacent) layers, as long as interaction of the respective protocol entities is possible. Consequently, vertical trading is able to overlap protocol entities that are not stimulated by any incentive scheme.

Incentive schemes and incentive patterns. If remunerations are traded vertically among incentive schemes that apply different incentive patterns, the traded remunerations have to be inter-assessed. Such an assessment may be integrated within the negotiation phase of the transaction [12]. Hence, heterogeneous incentive patterns do not pose considerable problems. Yet, we have to note that inter-assessment may be highly non-trivial in case of fundamental differences between the incentive patterns. For example, the inter-assessment of reputation based and account based incentive patterns has to cope with differing paradigms.

6 Vertical Integration in DIANE

In this section, we apply vertical integration to the ad hoc network of our DIANE project [9]. Therefore, we introduce the characteristics of the DIANE ad hoc network that are relevant to vertical integration. Then, we identify required incentive schemes and discuss means of integrating them.

6.1 The DIANE Ad Hoc Network

6.1.1 Project Goals and Requirements

Our project DIANE aims at facilitating the integrated use of students' devices that form an ad hoc network. Stimulation of cooperation constitutes only one of several topics that resides within the project scope. Nevertheless, other parts of the project rely on cooperative behavior in order to be effective.

Service discovery. Our current approaches that aim at efficient service discovery [9] [8] [7] [6] bring in complexity to the discovery protocol. On the one hand, such complexity is required in order to ensure the efficiency of the service discovery in an ad hoc network. On the other hand, a complex discovery protocol translates into a large set of required cooperative behavior and, thus, into a complex incentive scheme.

Provision and integration of services. The provision of application services demands for incentives that restrain profitable misbehavior in the application layer. Yet, incentives for the integrated provision and consumption of composite application services reside outside of the scope of this paper, since multi-party cooperation is not considered.

Efficient usage of services. Efficient cooperation on the application layer requires mechanisms that assess resources both statically and dynamically. Therefore, the application of flexible remuneration schemes is highly desirable.

Ad hoc networks. For the future, the availability of a ubiquitous infrastructure like UMTS is projected [16]. Even at present, there exists a WLAN infrastructure in our campus [5]. Yet, in the first step, the DIANE project is focussed on ad hoc networks that might be permanently disconnected from

any fixed infrastructure. Therefore, we aim at identifying the potentials and limits of such ad hoc networks. We believe that ad hoc networks remain relevant in the presence of infrastructure for a set of reasons, i.e. energy and bandwidth efficiency, anonymity, autonomy and locality.

Consequently, accessibility of certain entities cannot be assumed by the incentive scheme of DIANE. In general, cooperation is restricted to nearby devices.

Closely coupled networks. We expect that the students will make use of the ad hoc network in order to study collaboratively. In such a case, the collaborating students initiate a closely coupled network that differs from the original ad hoc network in several ways:

- The topology of a closely coupled network is more stable.
- The participating users cooperate and are at close quarters.
- Cooperation is localized and occurs frequently.
- The closely coupled network encompasses only a specific subset of cooperation on the application layer.

It seems promising to conceive a service discovery protocol that exploits the specifics of closely coupled networks. As a result, cooperation is vertically partitioned on the application and discovery layer.

User interface. Due to the students' differing needs and resources, we anticipate that the set of participating information appliances [11] is heterogeneous. Consequently, the user interface differs, since the respective device capabilities have to be taken into account. As a result, the accuracy of resource configuration and user-device interaction is restricted and varies among devices.

If a student possesses more than one device, it seems a promising idea to interact with a single device in order to configure the resources of the remaining devices that come with a limited user interface.

6.1.2 The DIANE Incentive Scheme

Regardless of whether WLAN or Bluetooth is applied, it is presumed that the *link layer* is hardwired and therefore goes beyond the scope of the incentive scheme for DIANE. Since the link protocol entities stick to standard protocols, they form a collective. In this context, trust accrues from the assumption that hardwired protocol entities cannot be altered. Such an assumption holds for our DIANE project, since alteration of hardware comes with costs and, thus, is likely to be unprofitable for the student.

For the *network layer* and *transport layer*, common protocols for ad hoc networks may be employed [15]. The same holds for the *discovery layer*. Yet, an additional discovery protocol for closely coupled networks has to be conceived, e.g. based on discovery in wired networks. The network, transport, and discovery protocol entities should be encompassed by the incentive scheme in order to be affected by the resource configuration, which is a prerequisite for efficiency.

Since DIANE is focused on application services, the *application layer* is the heart of the incentive scheme. It is expected that there will be several standard services and further custom services that are developed by students. Even standard

services may be considered as customizable. For instance, the capabilities of a document service depend on the documents that are offered.

Cooperation on the *user layer* becomes essential for closely coupled networks. Therefore, it has to be considered by the incentive scheme.

6.1.3 Example of Cooperation in DIANE

Figure 18 gives an example of cooperation in DIANE. User *R* and user *S* cooperate in a closely coupled network. Their cooperation is supported by an application A_2 , e.g. a white-board application. The discovery of other application services within the closely coupled network is facilitated by a specialized protocol D_C . We have to note that user *R* and *S* are not required to have a single hop distance.

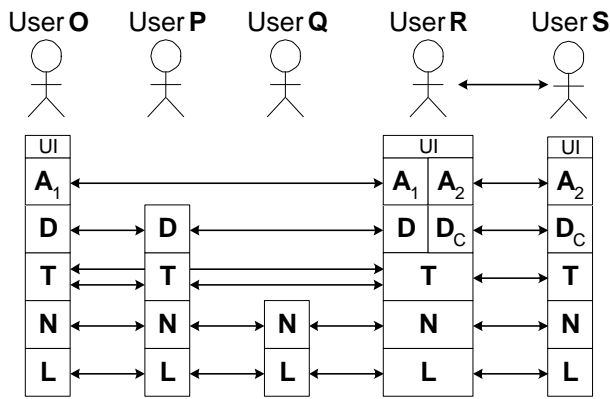

Figure 18. Example of cooperation in DIANE

Let us assume that, during collaboration, user *R* requires a document that resides on the device of user *O*. Therefore, the discovery protocol is run in order to find a document service A_1 that provides such a document. In the overlay of the discovery protocol D , the protocol entity of user *P* is adjacent to the protocol entity of user *R*, even though their distance is two hops and their packets have to be relayed by the network protocol entity of user *Q*.

The discovery protocol entity of user *P* has already been informed about the service A_1 by an advertisement of the discovery protocol entity of user *O*. Therefore, the discovery protocol entity of user *R* knows about the site of the document service.

Finally, the application protocol A_1 is run and user *R* retrieves the desired document. It is assumed that the document service skips the discovery layer in order to maintain a peer-to-peer connection on the transport layer. We have to note that user *R* and user *O* do not cooperate. User *O* might even be unaware of the transaction.

Dedicated link and network protocols could take advantage of the characteristics of closely coupled networks. Yet, the example assumes uniform link, network and transport protocols that do not distinguish between the original ad hoc network and the closely coupled network. In the following, this assumption is maintained, since partitioning on the net-

work layer would yield considerable complexity and overhead by necessitating bridges and gateways.

6.1.4 Incentive Patterns

As it comes to the choice of appropriate incentive patterns, the project environment imposes severe restrictions. The known implementations of *account based* incentive patterns cannot deal with such an environment, since neither the banker nodes of APE [2] nor the credit clearance system of Sprite [17] nor the security modules of TerminoNodes [3] are disposable [12]. Our project requires a remunerating incentive scheme that is able to integrate with the existing remunerating incentives for user cooperation. As a result, the reputation based incentive pattern fits best to the DIANE environment.

6.2 Vertical Integration of DIANE's Incentive Schemes

There is more than one possible decomposition of incentives for cooperation in DIANE into incentive schemes. Figure 18 suggests an incentive scheme for the original ad hoc network and one for closely coupled networks. On top of that, we propose one further incentive scheme for the network and transport cooperation domain.

The Integrated Network (IN) incentive scheme. Since closely coupled networks do not introduce vertical partitioning to the network and transport layer, it makes sense to conceive a separate incentive scheme, i.e. the IN scheme, for the network and transport layer. Furthermore, the implementation of the IN scheme may apply existing approaches for stimulated cooperation on the network and transport cooperation domain [12]. Since incentive schemes in DIANE have to be reputation based, the watchdog/pathrater, CONFIDANT, CORE or RPG approach or any future community based network oriented approach may be applied.

The Integrated Service (IS) incentive scheme. The IS incentive scheme stimulates cooperation in the discovery and application domain. From a user perspective, the discovery and usage of application services represents hidden cooperation, so that user cooperation is not explicit and is not stimulated by the IS scheme. Nevertheless, the IS scheme encompasses the user domain in order to enable vertical trading of remunerations between the user and his application protocol entity.

The Closely Coupled Network (CCN) incentive scheme. The CCN scheme stimulates student collaboration. It encompasses the cooperation on the discovery, application and user layer.

Vertical integration of incentive schemes. Vertical trading of remuneration occurs between the IN subscheme on the one hand and the IS and CCN subscheme on the other. Furthermore, horizontal trading between the IS subscheme and CCN subscheme is facilitated by the vertical partitioning of the discovery and application layer.

Inter-scheme trading of remunerations does not require inter-device and inter-domain transactions, since the respective incentive schemes all apply the reputation based incentive pattern. Therefore, only the inter-rating of remunerations between different incentive schemes has to be elaborated.

The IS scheme and the CCN scheme encompass the user layer. Therefore, vertical trading of remunerations between the user and the application protocol entity remains within the borders of the respective incentive scheme. We have to note that the user implicitly performs inter-scheme trading between the IS and CCN scheme, because he might be unaware of the vertical partitioning of the user layer.

The proposed incentive schemes are illustrated in Figure 1. Obviously, the cooperation domains are partitioned both vertically and horizontally. Vertical integration of the incentive schemes is rendered simple because of the homogeneity with regard to incentive patterns. In addition, the reputation based incentive pattern allows for localized trading of remunerations.

Usage Domain	application service centered ad hoc network	generic closely coupled network
User	IS incentive scheme	CCN incentive scheme
Application		
Discovery		
Transport	IN incentive scheme	
Network		
Link		

Table 1. Incentive Schemes in the DIANE ad hoc network

7 Conclusion

Recently, several approaches have been proposed that conceive incentives for the cooperation of autonomous devices in ad hoc networks. Yet, each approach is confined to a specific protocol layer and does not consider integration with other incentives. Therefore, in this paper, we examined the need for vertical integration of incentives for cooperation. It shows that vertical integration is a prerequisite for the effectiveness of every single incentive scheme. The basis for vertical integration is provided by vertical interaction that we augmented with vertical trading of remunerations. We made the relationship between cooperation and interaction explicit by combining their respective models into a generic model of stimulated cooperation. We exemplified the model and pointed out the interrelation of remunerations and resources. In order to examine the model's applicability, we identified different dimensions of heterogeneity that are found in practice. Consequently, we discussed the implementation of the model in such an environment. It shows that vertical trading of remunerations is feasible. Finally, we identified and integrated incentive schemes of our DIANE ad hoc network.

In the future, vertical integration of specific incentive schemes has to be considered and implemented. In this context, inter-assessment of different incentive patterns requires a thorough analysis. For our DIANE project, we aim at conceiving incentive schemes that are focussed on the discovery

and application cooperation domain, in order to make up for the lack of dedicated incentive schemes in these domains. At a later stage of our project, we will consider the integration with further incentive schemes.

REFERENCES

- [1] N. Asokan, Phillipe A. Janson, Michael Steiner, and Michael Waidner, 'The state of the art in electronic payment systems', *IEEE Computer*, **30**(9), 28–35, (1997).
- [2] M. Baker, E. Fratkin, D. Guitierrez, T. Li, Y. Liu, and V. Vijayaraghavan, 'Participation incentives for ad hoc networks'. <http://www.stanford.edu/~barretod>, 2001.
- [3] L. Buttyan and J. Hubaux, 'Nuglets: a virtual currency to stimulate cooperation in self-organized ad hoc networks', Technical report, EPFL, (2001).
- [4] K. E. Drexler and M. S. Miller, *The Ecology of Computation*, chapter Incentive Engineering for Computational Resource Management, B. Huberman (ed.), 1988.
- [5] DUKATH. Wireless Internet Access at the University of Karlsruhe., 2000. <http://www.uni-karlsruhe.de/Uni/RZ/Netze/DUKATH/dukath-engl.html>.
- [6] Michael Klein, Birgitta König-Ries, and Philipp Obreiter, 'Lanes – a lightweight overlay for service discovery in mobile ad hoc network', in *3rd Workshop on Applications and Services in Wireless Networks (ASWN2003)*. Berne, Swiss, (July 2003).
- [7] Michael Klein, Birgitta König-Ries, and Philipp Obreiter, 'Service rings – a semantical overlay for service discovery in ad hoc networks', in *The Sixth International Workshop on Network-Based Information Systems (NBIS2003)*, Workshop at DEXA 2003, Prague, Czech Republic, (September 2003).
- [8] M. Klein and B. König-Ries, 'Multi-layer clusters in ad-hoc networks - an approach to service discovery', in *Proceedings of the First International Workshop on Peer-to-Peer Computing (Co-Located with Networking 2002)*, Pisa, Italy, pp. 187–201, (2002).
- [9] B. König-Ries and M. Klein, 'Information services to support e-learning in ad-hoc networks', in *First International Workshop on Wireless Information Systems (WIS2002)*, pp. 13–24, (2002).
- [10] Chen Lee, John Lehoczky, Ragunathan Rajkumar, and Dan Siewiorek, 'On Quality of Service Optimization with Discrete QoS Options', in *IEEE Real Time Technology and Applications Symposium*, pp. 276–285, (1999).
- [11] D. A. Norman, *The Invisible Computer*, MIT Press, Cambridge, MA, 1998.
- [12] Philipp Obreiter, Birgitta König-Ries, and Michael Klein, 'Stimulating cooperative behavior of autonomous devices - an analysis of requirements and existing approaches', in *Second International Workshop on Wireless Information Systems (WIS2003)*, pp. 71–82, (2003).
- [13] Philipp Obreiter, Birgitta König-Ries, and Michael Klein, 'Stimulating cooperative behavior of autonomous devices - an analysis of requirements and existing approaches', Technical Report 2003-1, Universität Karlsruhe, Faculty of Informatics, (January 2003).
- [14] Philipp Obreiter and Jens Nimis, 'A taxonomy of incentive patterns - the design space of incentives for cooperation', in *Proceedings of the Second International Workshop on Agents and Peer-to-Peer Computing (AP2PC'03)*, Melbourne, Australia, (2003).
- [15] E. Royer and C. Toh, 'A review of current routing protocols for ad-hoc mobile wireless networks', *IEEE Personal Communications*, (April 1999).
- [16] UMTS, 2003. <http://www.umts-forum.org>.
- [17] Sheng Zhong, Jiang Chen, and Yang Richard Yang, 'Sprite: A simple, cheat-proof, credit-based system for mobile ad-hoc networks', in *Proceedings of IEEE Infocom'03*, San Francisco, CA, (April 2003).